

# Classic Split Six Scraper

**The ultimate finishing scraper.**

The Classic Split Six is a sophisticated and extremely gentle blade designed exclusively for our Split Six Scraper.

Split Six blades are 6" wide at the base for support and to prevent them from spreading apart. Each blade is split into two 3" wide segments which flex to create a

gentle, finger-like cleaning action – perfect for finishing operations and as an efficient water squeegee. Cleaning blades are available with or without tungsten carbide inserts. Both right and left end blades are molded with a urethane blade tip segment to allow for belt cupping and to prevent damage to the outer edges of the conveyor belt.

The scraper utilizes a simple design with a 2-bolt, quick-change blade cartridge. Split Six blades have an aluminum track molded into the base to give support for bolting to the cartridge and to prevent bolt tear out.

Tensioning is provided by reliable spring **tensioners on both sides**. Rotary tensioning action allows belt splices to pass freely

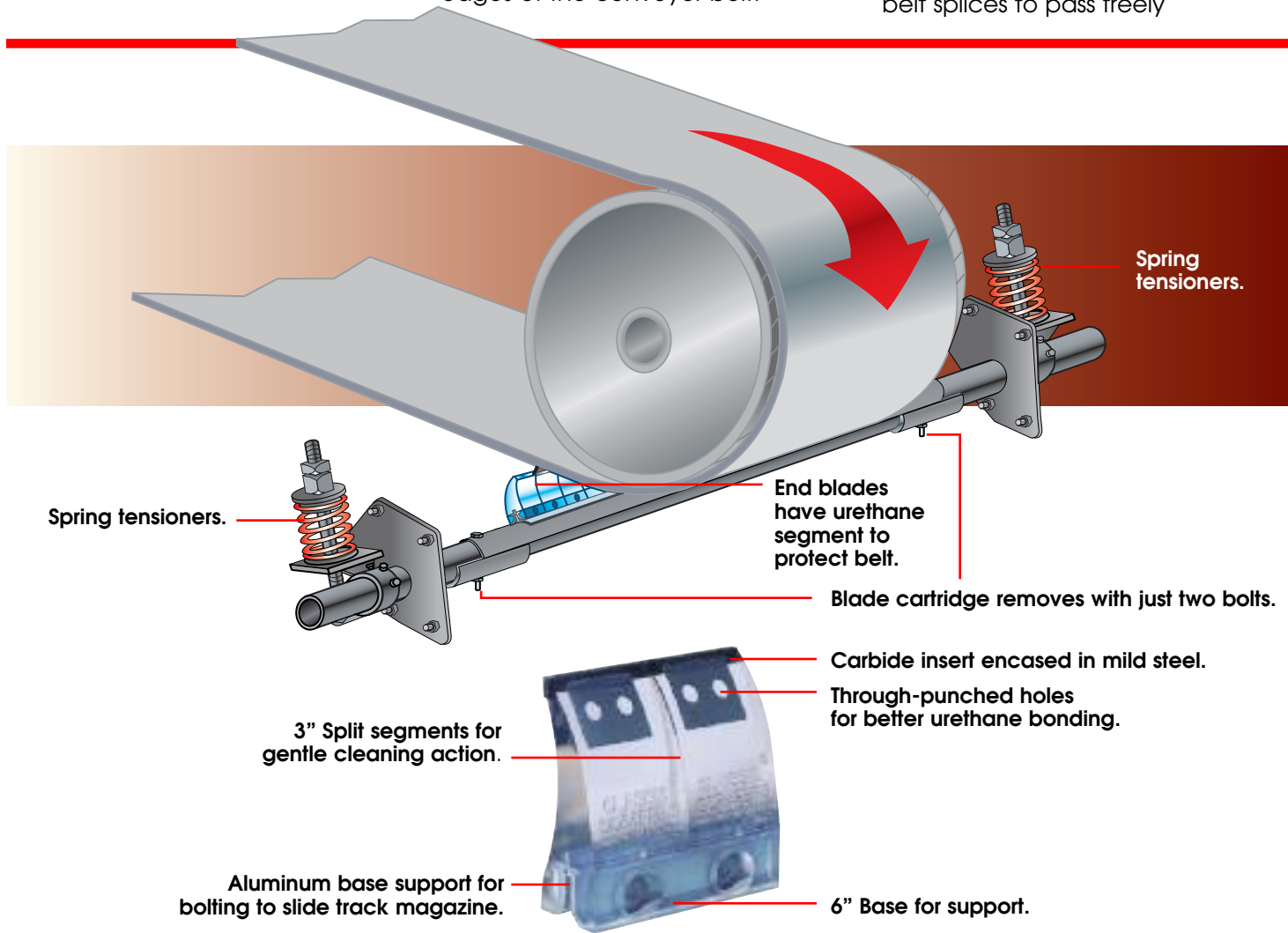

## Classic Split Six Scrapers

DIMENSIONS NEEDED  
WHEN ORDERING

- A — CHUTE WIDTH (outside)
- B — CHUTE WIDTH (inside)
- C — BELT WIDTH

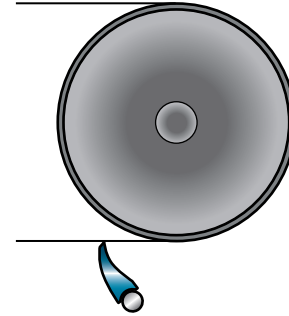
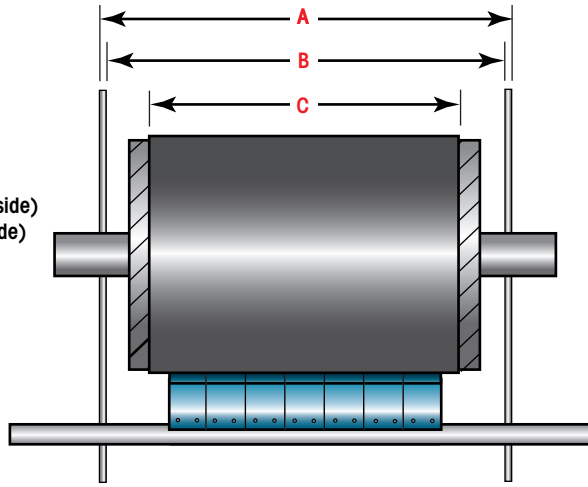

Belt Width (inches)	Blade Coverage (inches)	Tube Length (inches)	Assembly Part Number	
			Carbide Blades	Urethane Blades
18	12	72	CSSS-18-T	CCSSS18-U
24	18	78	CSSS-24-T	CCSSS-24-U
30	24	84	CSSS-30-T	CCSSS-30-U
36	30	90	CSSS-36-T	CCSSS-36-U
42	36	96	CSSS-42-T	CCSSS-42-U
48	42	102	CSSS-48-T	CCSSS-48-U
54	48	108	CSSS-54-T	CCSSS-54-U
60	54	114	CSSS-60-T	CCSSS-60-U

Available in any conveyor belt size upon request.

**Notes:**

- Please specify if desired blade coverage differs from chart above.
- Custom tube lengths can be supplied upon request.
- Assembly includes Classic Split Six Scraper unit with individual blades, mounting plates and tensioning springs.

### ACCESSORIES

Part Number	Description
CS090-6	Replacement Blade 6" Tungsten Carbide
CS090-6-U	Replacement Blade 6" Urethane
CS090-6-R	Right End Blade 6" Urethane
CS090-6-L	Left End Blade 6" Urethane

Let us convey answers to your questions.

We have many years of experience in working with conveyor systems. We'd be happy to share our knowledge with you. Please call if you have any technical questions or need information on handling special materials.

Chances are we can answer your question immediately over the phone. If not, we'll gladly research the problem and get back to you with a solution as quickly as possible.



P.O. Box 38 • 120 Airport Road  
Blairsville, PA 15717  
Phone: 724-459-5261 • Fax: 724-459-5605  
www.classicconveyor.com

